

# Crocodile head with undergum twists

Roberto Gretter, autumn 2001

With a rectangle having size 70 x 17 cm you will get a crocodile head about 20 cm long, having 5 rows of teeth. Best results with elephant skin paper, but I strongly suspect that crocodile skin paper could be better :-)

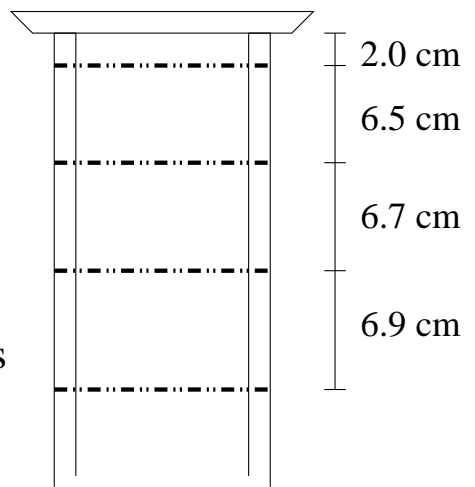
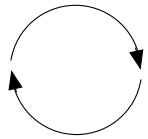
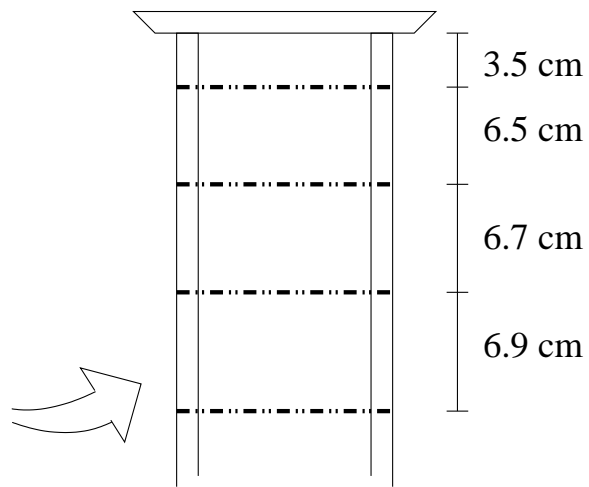
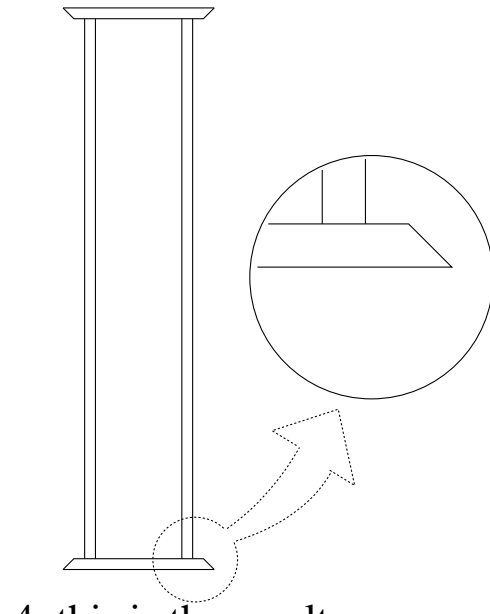
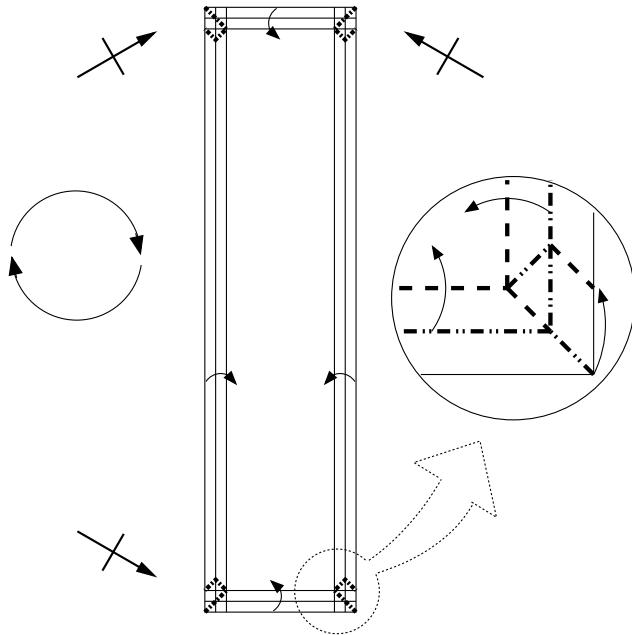
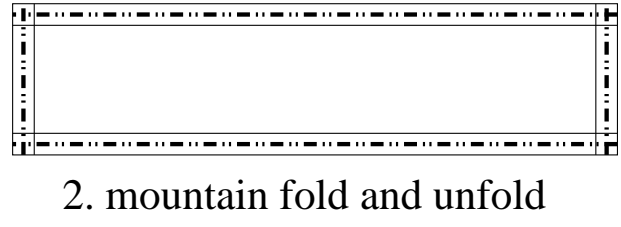
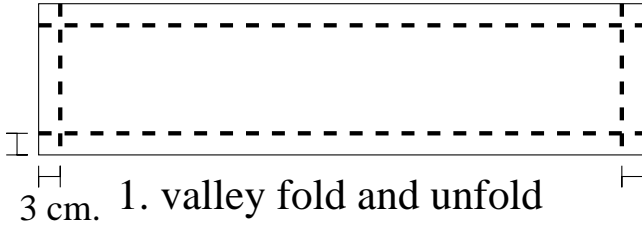

5. lower jaw: mark the position of the teeth (these measures are just an indication)

6. upper jaw (creases are moved up compared to step 5, to obtain upper teeth alternate to the lower ones)

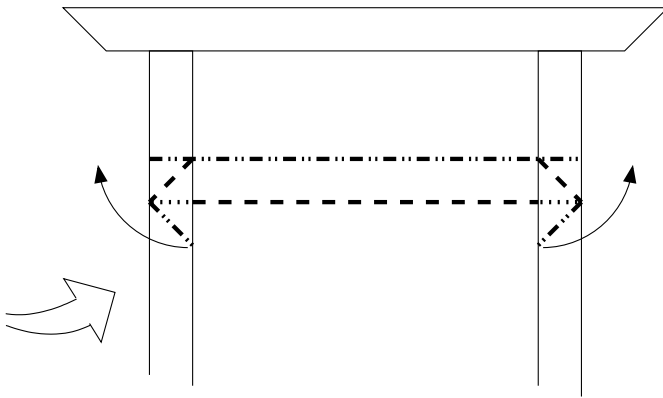

7. first tooth: open to set up the creases of the undergengival twist

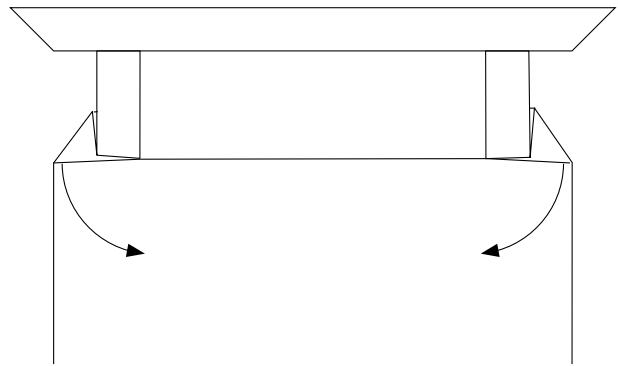

8. close and repeat step 7 on the other 3 upper teeth

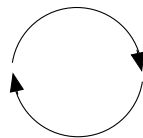

9. turn and repeat steps 7, 8 on the upper teeth, then reopen the model completely and reverse some of the creases as indicated; note that the lower teeth are turned upside down (see step 10)

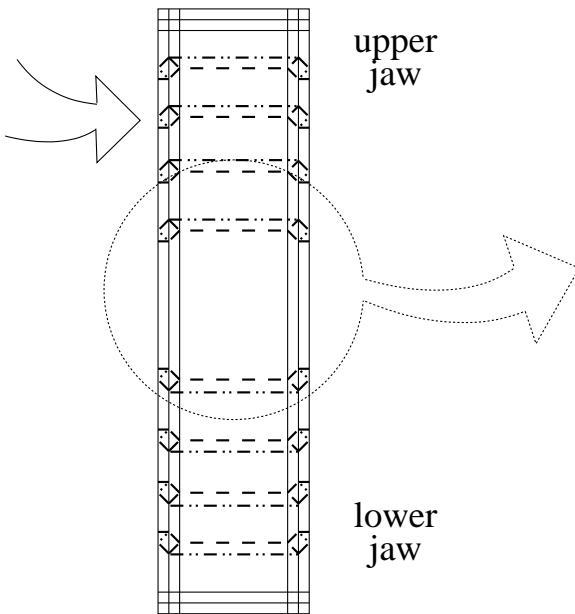
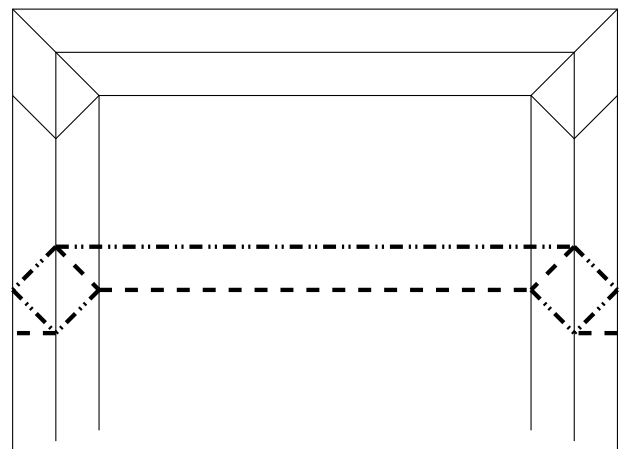

10. execute the twists starting from the innermost teeth pairs and going toward the outside

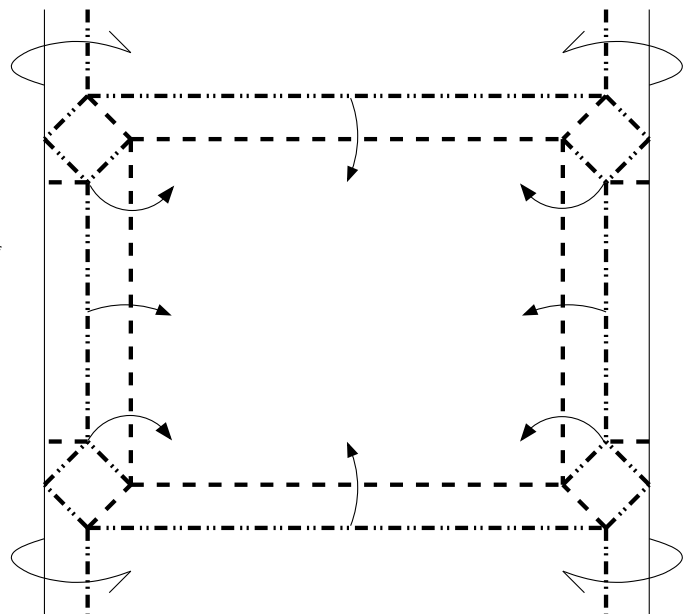

11. first 4 twists; do not close the paper outside the shown zone

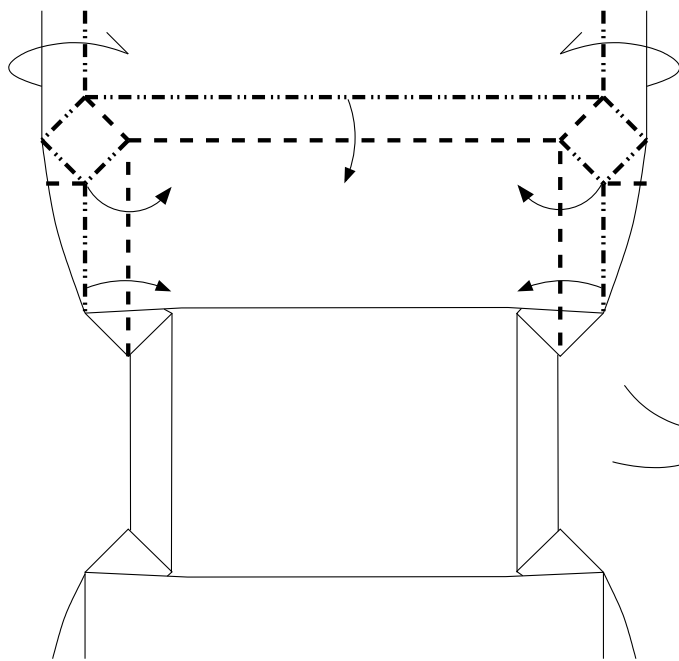

12. the first 4 twists are done, now go on with all of the others (only the next one is shown)

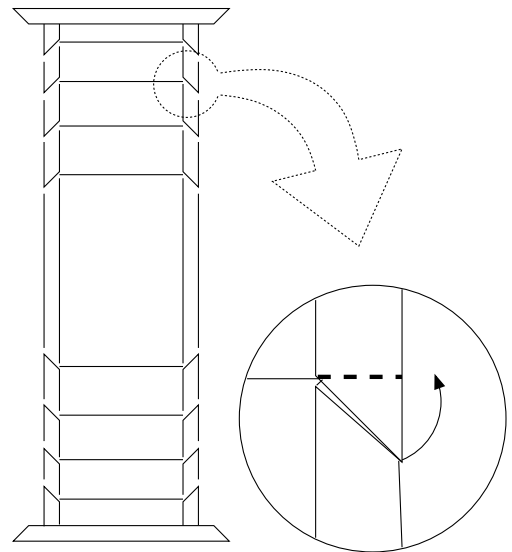

13. on the boundaries, reform the creases as in step 3; bring the teeth up at 90 degrees

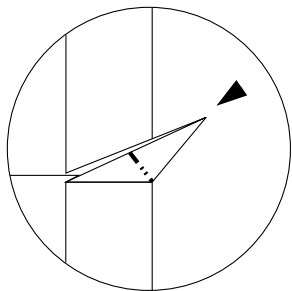

14. squash fold

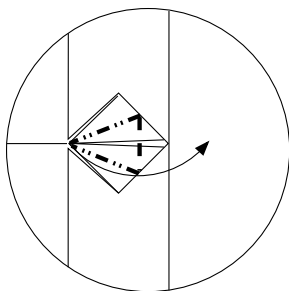

15. petal fold

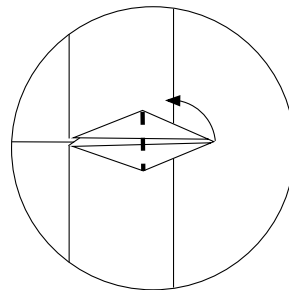

16. up at 90 degrees

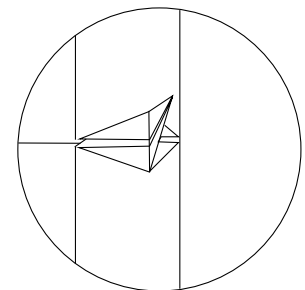

17. repeat 13–16 on each lateral tooth

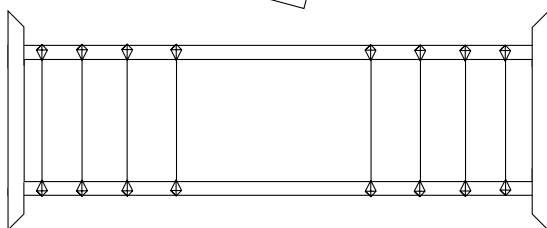
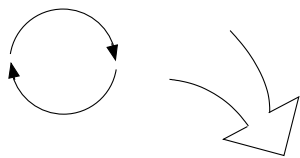

18. overview

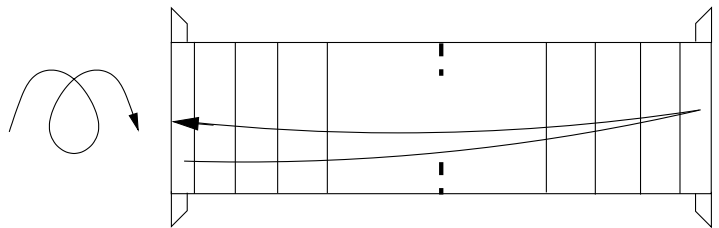

19. pinch the midpoint

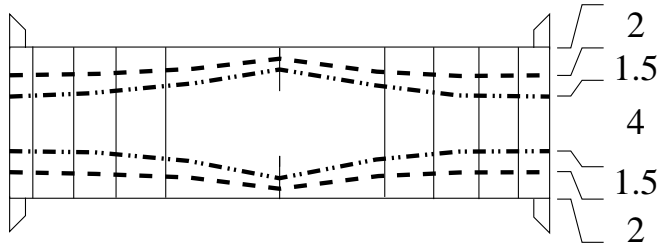

20. measures are just an indication except 1.5, used for the next twists (the short side is 11 cm); note that the creases are a bit curved

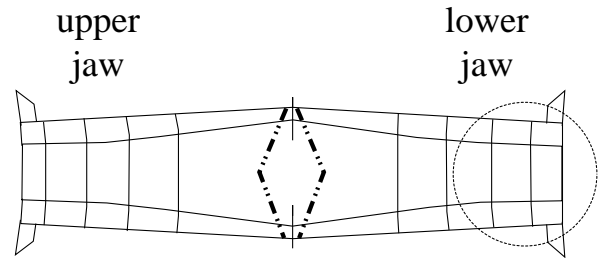

21. precrease a rhomb in the middle

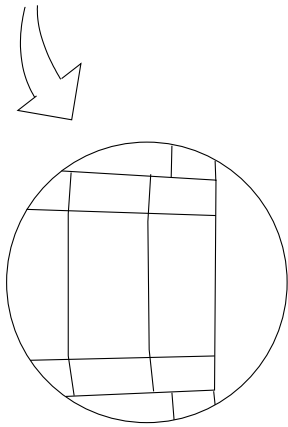

22. turn the model

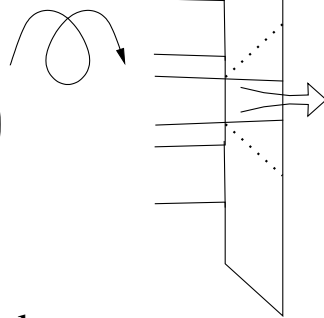

23. pop the paper in the middle up

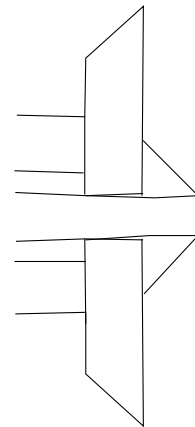

24. reopen the forward section

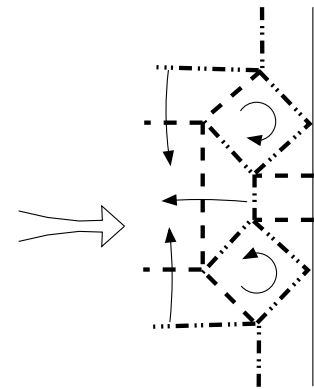

25. go on with the next twists

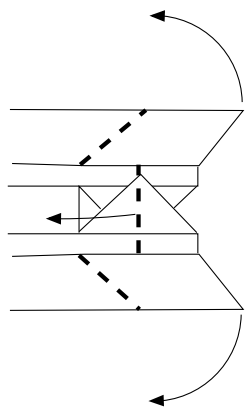

26. close

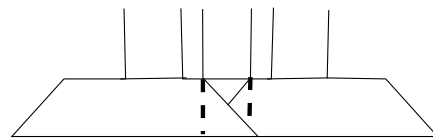
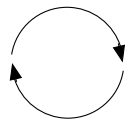

27. repeat steps 13–16 on the forward teeth; repeat steps 23–27 on the upper jaw

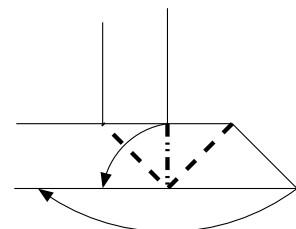

28. corner tooth: squash fold

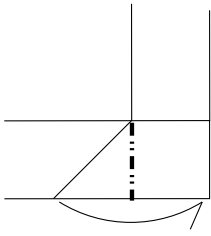

29. put the flap inside

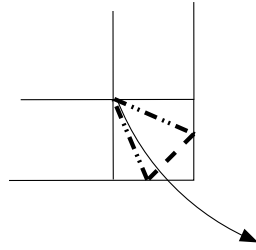

30. petal fold

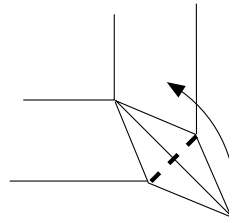

31. bring up at 90 degrees

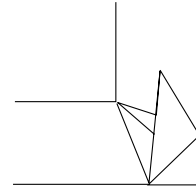

32. repeat steps 28–31 on the other 3 corner teeth

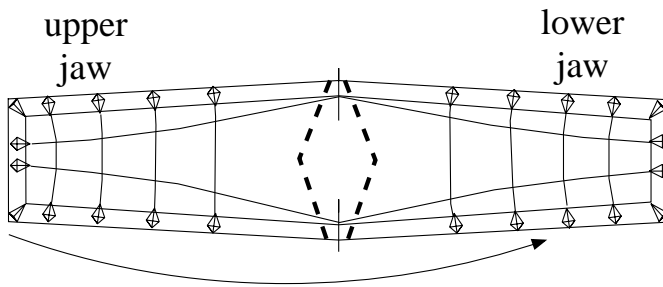

33. close the model in half (it becomes 3-D)

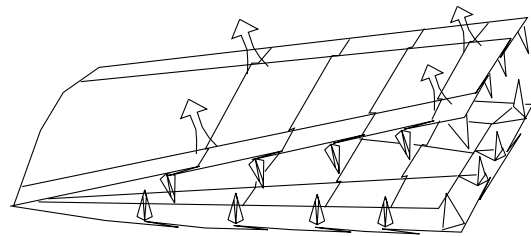

34. extract some loose paper to form eyes and nostrils

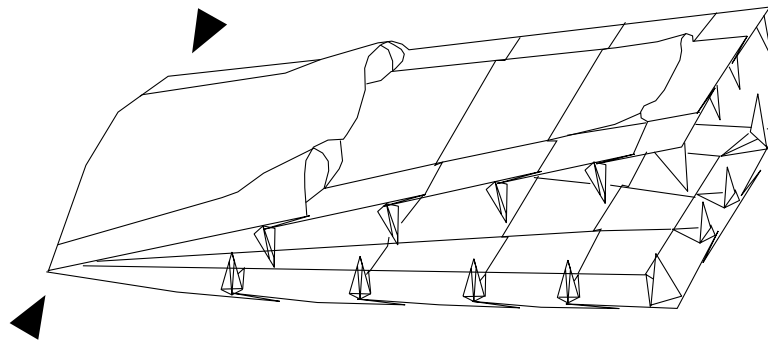

35. crocodile head with undergum twists; press as indicated to make it open and close